

IT2100F

The IT2100F employs an analogue ASIC for the oscillator and a high order temperature compensation circuit in a 2.0 x 1.6 mm size package. The device can be placed in power down mode through a single input pin. During standard operation, power consumption is minimised by operating down to a supply voltage of 1.8V. The IT2100F's high stability, low power consumption, small footprint and powerful compensation method makes it a TCXO ideally suited for demanding GNSS mobile applications.

Features

- Excellent phase noise performance
- Low start up drift rate
- Height less than 0.8 mm
- Power down mode
- Standard temperature stability of ± 0.5 ppm over wide temperature ranges

Applications

- **Time and frequency reference**
 - GNSS
 - Smartphone
 - Communications
 - Consumer

2.0 x 1.6 mm



Standard Specifications

Parameter	Min.	Typ.	Max.	Unit	Test Condition / Description
Nominal frequency		13 - 52		MHz	
Frequency calibration			± 1	ppm	Offset from nominal frequency measured at 25°C $\pm 2^\circ\text{C}$
Reflow shift			± 1	ppm	Two consecutive reflows as per attached profile after 2 hours relaxation at 25°C
Operating temperature range	-40		85	°C	The operating temperature range over which the frequency stability is measured
Frequency stability over temperature			$\pm 0.5 - \pm 2$	ppm	Referenced to the midpoint between minimum and maximum frequency value over the specified temperature range ¹ . Control voltage set to midpoint of Vc
Frequency slope			$\pm 0.05 - \pm 1$	ppm/°C	Minimum of one frequency reading every 2°C over the operating temperature range ¹
Static temperature hysteresis			0.6	ppm	Frequency change after reciprocal temperature ramped over the operating range. Frequency measured before and after at 25°C
Sensitivity to supply voltage variations			± 0.1	ppm	V _{DD} varied $\pm 5\%$ at 25°C
Sensitivity to load variations			± 0.2	ppm	$\pm 10\%$ load change at 25°C
Long term stability			± 1	ppm	Frequency drift over 1 year at 25°C
Supply voltage (V _{DD})		1.8 - 3.3		V	With a tolerance of $\pm 5\%$
Supply current			2.2	mA	At minimum V _{DD}
Control voltage (Vc) range V _{DD} \leq 2.3 V	0.3		1.5	V	The nominal Vc value is midway between the minimum and maximum. Voltage control should not exceed the V _{DD} +0.2 V or GND
Control voltage (Vc) range V _{DD} > 2.3 V	0.4		2.4	V	The nominal Vc value is midway between the minimum and maximum. Voltage control should not exceed the V _{DD} +0.2 V or GND
Frequency tuning	$\pm 6 - \pm 30$			ppm	Frequency shift from minimum to maximum Vc
Linearity			10	%	Deviation from straight line curve fit
Control voltage input resistance		500		k Ω	Measured between Vc and GND pin

¹ Parts should be shielded from drafts causing unexpected thermal gradients. Temperature changes due to ambient air currents on the oscillator can lead to short term frequency drift.

Model Outline and Recommended Pad Layout

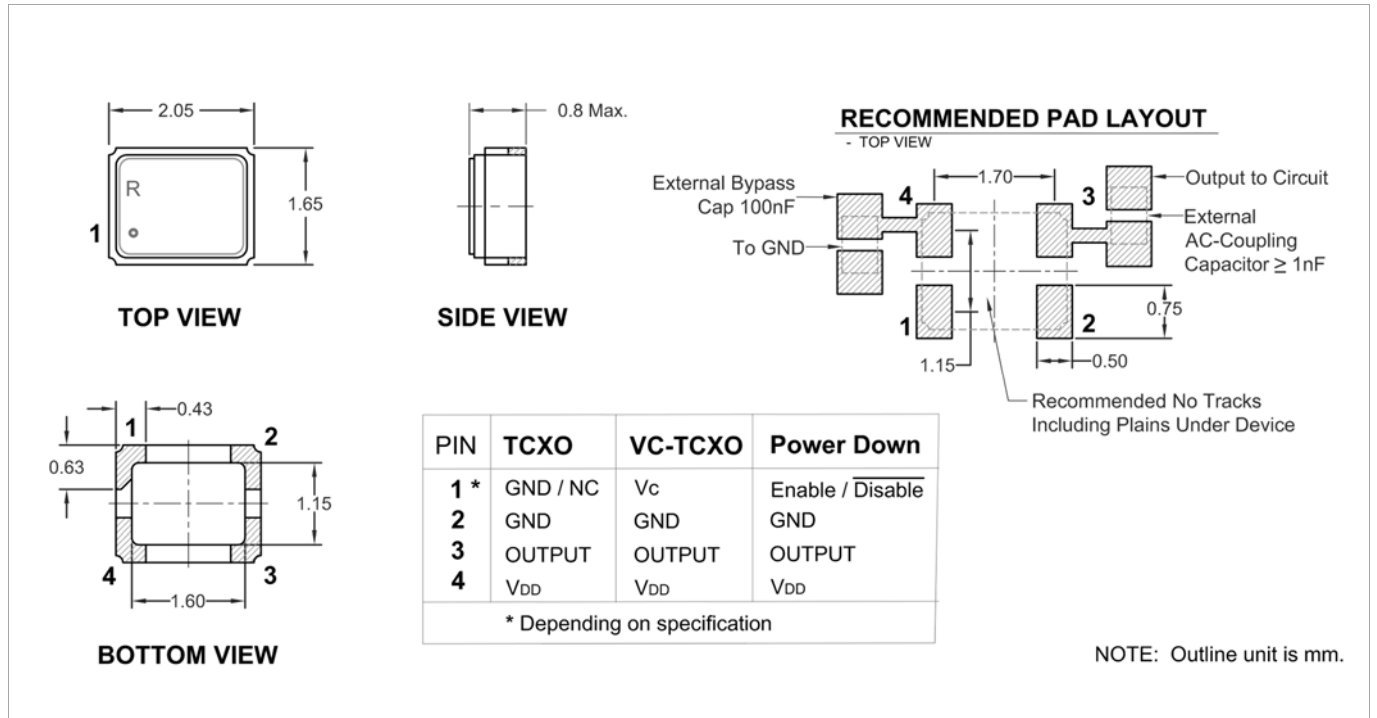

Test Circuit

